

IN-LINE MIXED FLOW DUCT FANS

TD-MIXVENT Series



Range of **low profile** in-line mixed flow duct fans manufactured in tough reinforced **plastic** (from 160 to 800 models) or with metal casing steel finished in a tough epoxy-polyester paint coating (from 1000 to 6000 models). The unique design of the support bracket allows the motor and impeller assembly to be fitted or removed without dismantling the adjacent ducting. IP44.

Motors

160 – 2000 models: Class B, with ball bearings and safety thermal overload protection.

Direct 2-speed connection and also suitable for voltage speed control.

Electrical supply:

Single phase 230V 50/60Hz.

4000 and 6000 models: Class F, with ball bearings and safety thermal overload protection.

Suitable for voltage speed control.

Electrical supply:

Single phase 230V 50/60Hz.

Additional Information

Three phase models adjustable by inverter control.

TD-MIXVENT-T models

TD-MIXVENT versions fitted with a **run-on-timer adjustable** within 1 and 30 minutes and one-speed motor not suitable for speed control.



The MIXVENT-TD fans offer the ideal in-line duct fan solution for a wide range of general residential or commercial ventilation application into.



Low profile

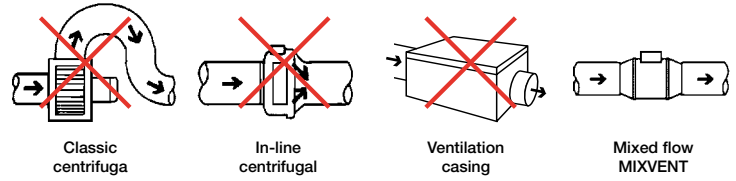

The low profile of the MIXVENT-TD fans makes them the most effective solution for installations where the space of installation is limited such as false ceilings.

Easy to mount



Fix the support bracket



Place the impeller and motor assembly



Carry out the wiring connections



Connect the ducts

Easy maintenance

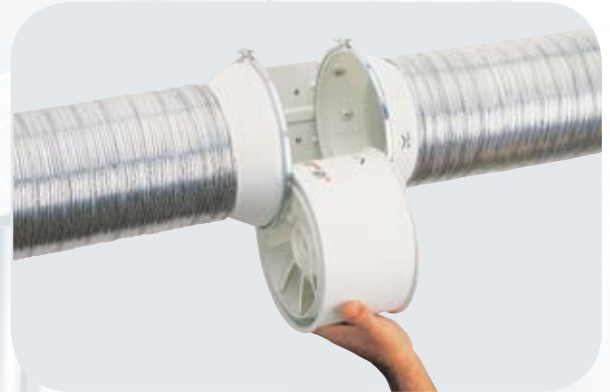

The unique design of the support bracket allows the motor and impeller assembly to be fitted or removed without dismantling the adjacent ducting

Flexible mounting position

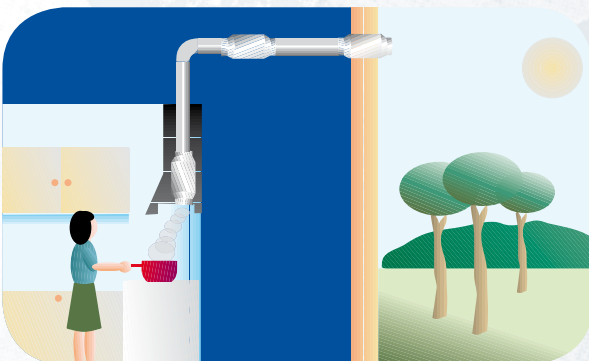

Can be mounted at any place of the air duct

Models with Run-On-Timer



MIXVENT-TD-T models (from 160 to 800 models) are fitted with an adjustable timer between 1 and 30 minutes and are supplied with a one-speed motor not suitable for speed control

Low noise level



TD-160/100N SILENT model offer very low noise level, with a **motor mounted on silent-elastic-blocks** which absorb the vibrations

■ Design characteristics

The MIXVENT-TD range provides a large number of solutions for small and large ventilation installations.

	160	250	350	500	800	800N	1000	1300	2000	4000	6000
Polypropylene casing	•	•	•	•	•	•					
Steel casing							•	•	•	•	•
ABS impeller	•	•	•	•	•	•					
Aluminium impeller							•	•	•	• ⁽¹⁾	• ⁽¹⁾
Protection class	II	II	II	II	II	II	I	I	I	I	I
Thermal protection by fuse	•	•	•								
Manual resetting thermal protector (PTC)				•	•	•	•	•	•	•	•
Ball bearings greased for life	•	•	•	•	•	•	•	•	•	•	•
1 speed controllable motor										•	•
2 speed controllable (2) motor	•	•	•	•	•	•	•	•	•		

(1) Models from one piece die cast aluminium impeller. (2) Models with Run-On-Timer fitted (TD-MIXVENT-T) are not controllable.

■ Technical characteristics

TD-MIXVENT	Speed (r.p.m.)	Maximum power absorbed (W)	Maximum absorbed current (A)	Airflow at free discharge (m³/h)	Maximum operating temperature (°C)	Sound pressure level* (dB(A))	Ø Duct (mm)	Weight (Kg)	Possible speed controllable
TD-160/100 N SILENT	2500	20	0,16	180	-20/+40	24	100	1,4	RMB-1,5 / REB-1
	2200	12	0,10	140		21			
TD-250/100	2200	24	0,11	240	-20/+40	31	100	2,0	RMB-1,5 / REB-1
	1850	18	0,10	180		26			
TD-350/125	2250	30	0,13	360	-20/+40	33	125	2,0	RMB-1,5 / REB-1
	1900	22	0,10	280		28			
TD-500/150	2500	50	0,22	580	-20/+60	33	150	2,7	RMB-1,5 / REB-1
	1950	44	0,19	430		29			
TD-500/160	2500	50	0,22	580	-20/+60	33	160	2,7	RMB-1,5 / REB-1
	1950	44	0,19	430		29			
TD-800/200N	2780	95	0,45	880	-20/+60	37	200	4,9	RMB-1,5 / REB-1
	2480	90	0,43	700		33			
TD-800/200	2500	120	0,50	1100	-20/+60	39	200	4,9	RMB-1,5 / REB-1
	2000	100	0,45	800		33			
TD-1000/250	2800	125	0,50	1010	-40/+60	40	250	9,4	RMB-1,5 / REB-1
	2610	85	0,35	900		38			
TD-1300/250	2520	180	0,80	1300	-40/+60	43	250	9,4	RMB-1,5 / REB-1
	2000	140	0,60	1100		39			
TD-2000/315	2700	255	1,20	2000	-40/+60	47	315	14,0	RMB-1,5 / REB-2,5
	2000	160	0,80	1550		42			
TD-4000/355	1400	345	1,53	3800	-40/+40	44	355	19,0	RMB-3,5 / REB-2,5
TD-6000/400	1400	665	2,97	5500	-40/+40	44	400	26,0	RMB-8 / REB-5

THREE PHASE

TD-4000/355 TRIF	1375	345	0,75	3800	-40/+40	44	355	19,0	RMT-1,5
TD-6000/400 TRIF	1375	650	2,10	5500	-40/+40	44	400	26,0	RMT-2,5

* Sound pressure level radiated at 3 m at free air conditions with rigid ducts at the inlet and at the outlet.

TD-MIXVENT-T	Speed (r.p.m.)	Maximum power absorbed (W)	Maximum absorbed current (A)	Airflow at free discharge (m³/h)	Maximum operating temperature (°C)	Sound pressure level* (dB(A))	Ø Duct (mm)	Weight (kg)
TD-160/100 NT SILENT	2500	20	0,16	180	40	24	100	1,4
TD-250/100 T	2200	24	0,11	240	40	31	100	2,0
TD-350/125 T	2250	30	0,13	360	40	33	125	2,0
TD-500/150 T	2500	50	0,22	580	60	33	150	2,7
TD-500/160 T	2500	50	0,22	580	60	33	160	2,7
TD-800/200N T	2500	120	0,50	1100	60	39	200	4,9

* Sound pressure level radiated at 3 m at free air conditions with rigid ducts at the inlet and at the outlet.

■ **Acoustic power spectrum in dB(A), for every frequency band, at the inlet and radiated, at high speed**

AT INLET	63	125	250	500	1100	2000	4000	8000
TD-160/100 N SILENT	24	32	39	46	52	49	40	21
TD-250/100	28	47	46	53	52	47	39	33
TD-350/125	35	47	46	53	54	59	41	33
TD-500/150	32	35	55	57	59	62	56	48
TD-500/160	32	35	55	57	59	62	56	48
TD-800/200N	37	42	62	64	66	64	60	52
TD-800/200	37	47	61	63	68	67	64	54
TD-1000/250	35	45	58	66	72	69	62	54
TD-1300/250	37	52	64	67	75	73	66	61
TD-2000/315	41	57	66	71	77	74	67	62
TD-4000/355	40	49	61	66	73	70	66	57
TD-6000/400	43	56	67	72	76	74	69	60

RADIATED	63	125	250	500	1100	2000	4000	8000
TD-160/100 N SILENT	24	24	37	34	36	41	32	21
TD-250/100	27	46	45	44	43	43	32	25
TD-350/125	33	46	46	47	47	45	33	24
TD-500/150	25	32	43	39	44	53	42	29
TD-500/160	25	32	43	39	44	53	42	29
TD-800/200N	26	32	48	47	52	53	44	31
TD-800/200	29	36	47	46	54	57	48	33
TD-1000/250	23	34	44	46	58	57	46	43
TD-1300/250	22	36	39	47	60	59	52	47
TD-2000/315	29	41	52	55	64	63	57	53
TD-4000/355	31	49	55	55	63	57	51	40
TD-6000/400	30	53	59	55	61	55	54	45

■ **Dimensions (mm)**

TD-160/100 N SILENT

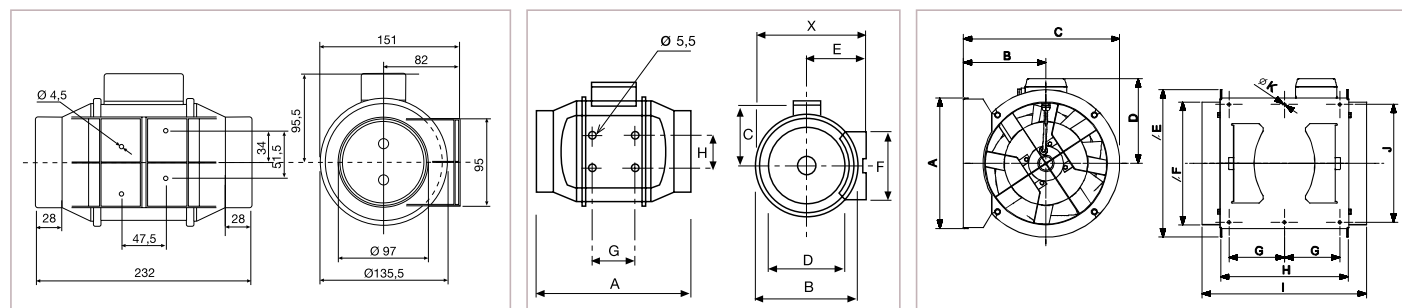

Model	X	A	ØB	C	ØD	E	F	G	H
TD-250/100	188	303	176	115	97	100	90	80	60
TD-350/125	188	258	176	115	123	100	90	80	60
TD-500/150	212	295	200	127	147	112	130	80	60
TD-500/160	212	295	200	127	157	112	130	80	60
TD-800/200N	232,5	302	217	141	198	124	140	100	94
TD-800/200	232,5	302	217	141	198	124	140	100	94
TD-1000/250	291	386	272	192	248	155	168	145	140
TD-1300/250	291	386	272	192	248	155	168	145	140
TD-2000/315	356	450	336	224	312	188	210	182	178

Model	A	B	C	D	øE	øF	G	H	I	J	øK
TD-4000/355	377	238	451	224	426	354	150	368	474	340	8.5
TD-6000/400	407	249	492	267	487	399	160	425	547	370	8.5

■ **Accessories (see TD-MIXVENT Installation accessories)**

Performance curves

- Q = Air volume in, m³/hr and m³/s.
- Ps = Static pressure in mmWG and Pa.
- Dry air at 20°C and 760 mmHg.
- Performance data in accordance with ISO 5801 and AMCA 210-99 Standards.

HS = High speed
LS = Low speed

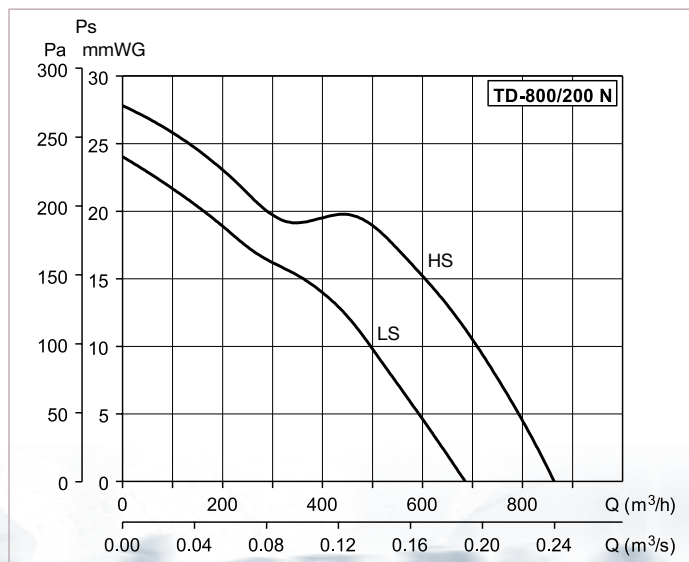
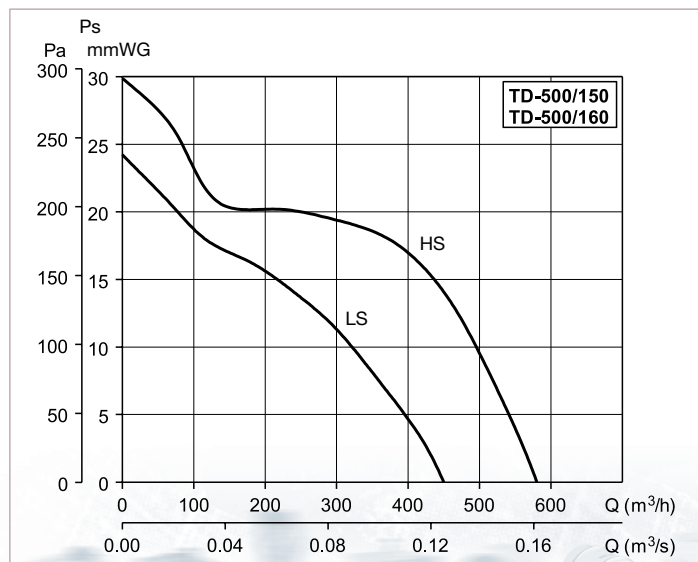
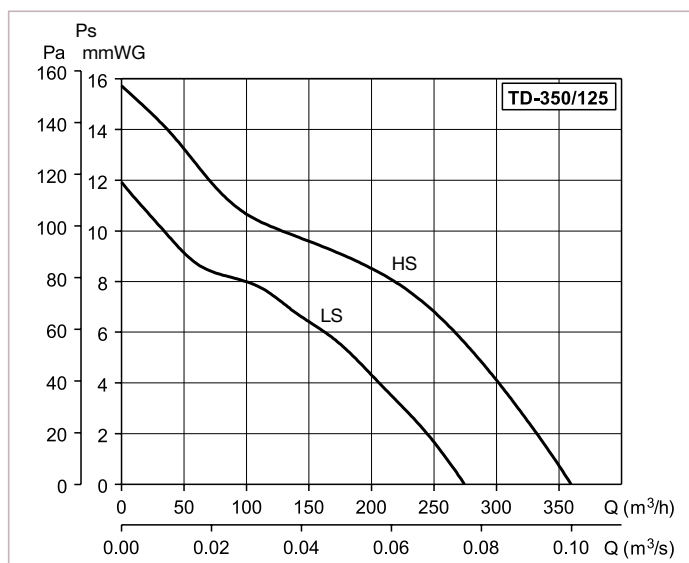
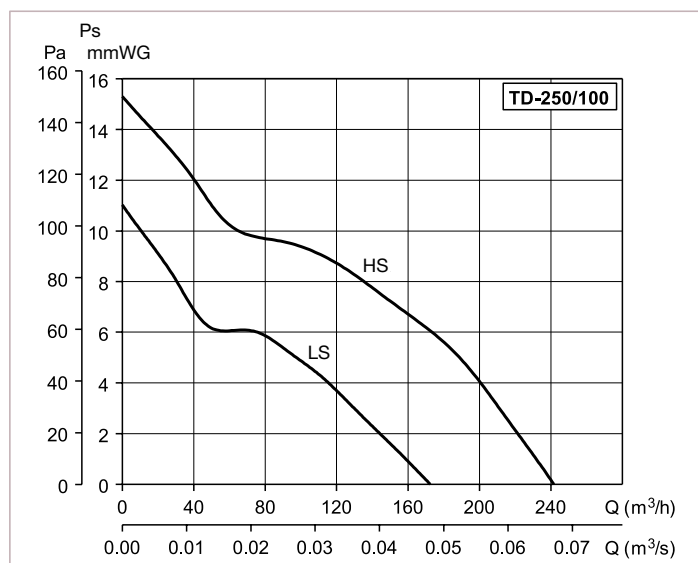
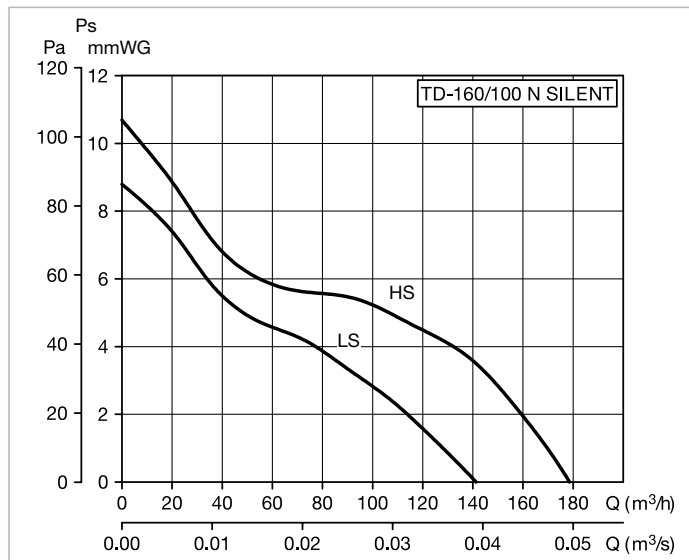

■ Performance curves

- Q = Air volume in, m³/hr and m³/s.
- Ps = Static pressure in mmWG and Pa.
- Dry air at 20°C and 760 mmHg.
- Performance data in accordance with ISO 5801 and AMCA 210-99 Standards.

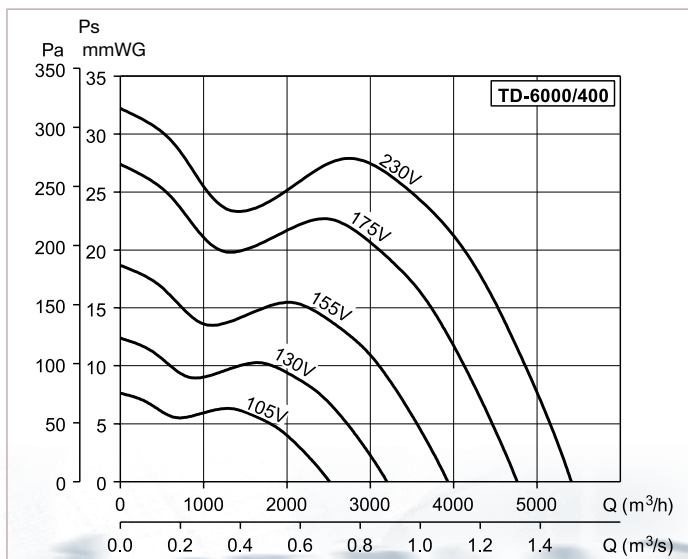
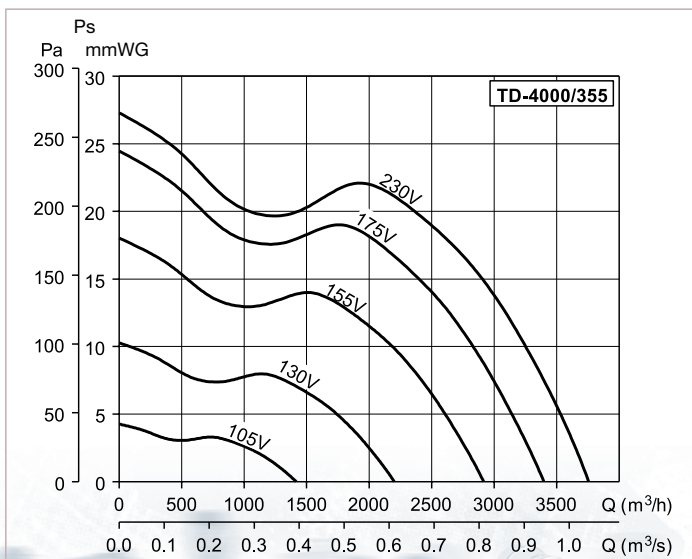
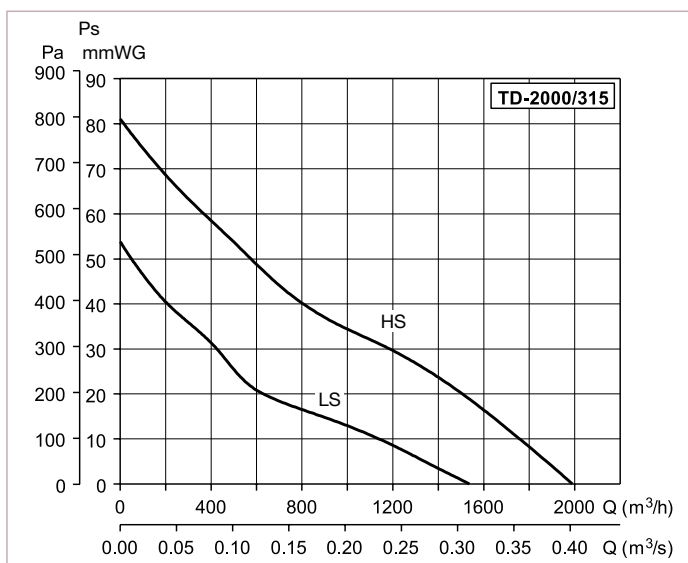
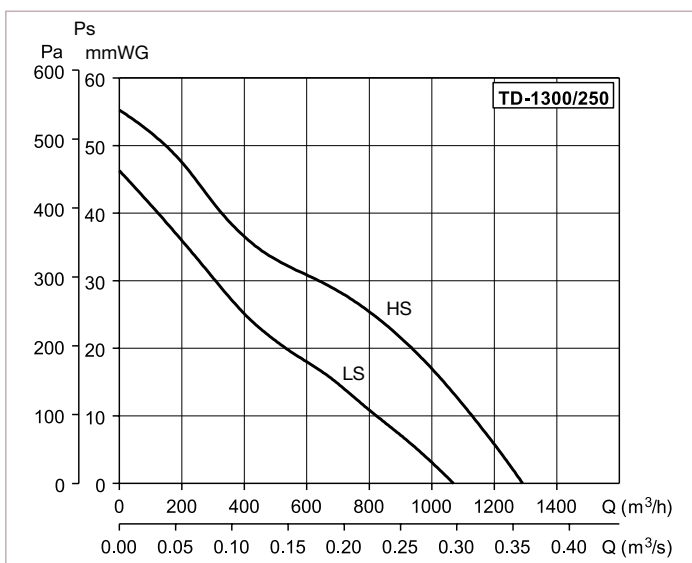
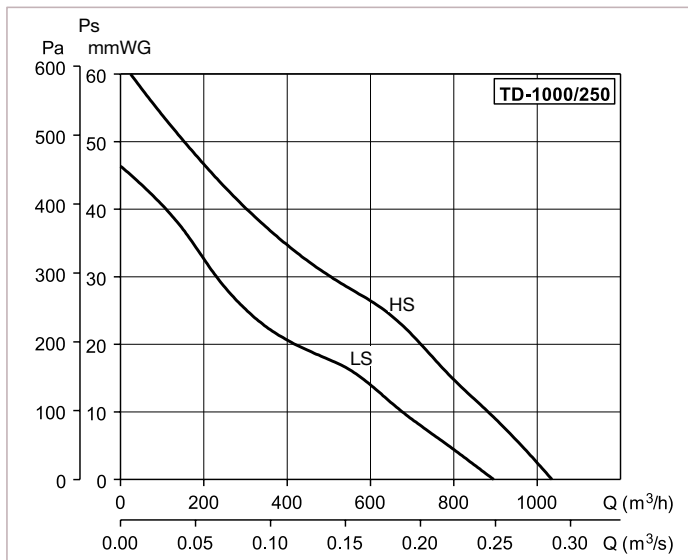
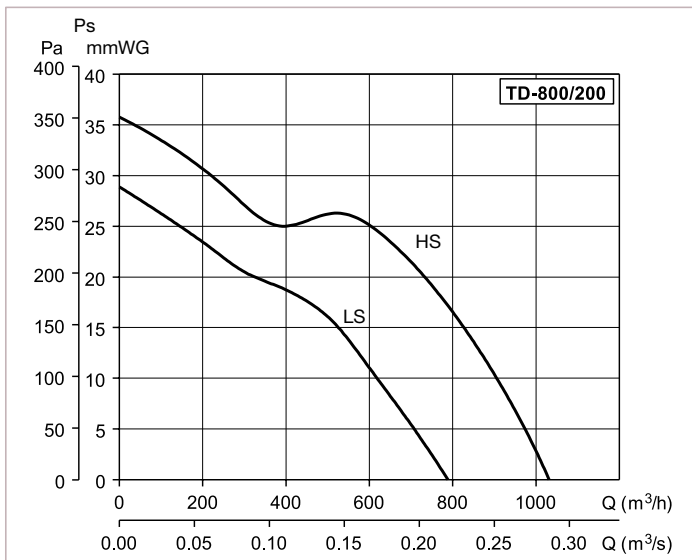

In-Line mixed flow duct fans

The TD ventilation kits enable the simple and fast installation of a complete ventilation system. The kits provide efficient extraction for bathrooms, toilets, washrooms and any other applications that require the removal of bad odours, stuffy and humid air.

3 kits are available:

KIT TD-160/100 N SILENT includes:

- 1 TD-160/100 N SILENT fan
- + 4 m of flexible aluminium ducting GSA-100
- + 1 interior circular air valve BOR-100
- + 1 exterior mounted grille GR-100
- + 1 adhesive duct tape BA

KIT TD-250/100 includes:

- 1 TD-250/100 fan
- + 4 m of flexible aluminium ducting GSA-100
- + 1 interior circular air valve BOR-100
- + 1 exterior mounted grille GR-100
- + 1 adhesive duct tape BA

KIT TD-250/100T includes:

- 1 TD-250/100 T fan
- + 4 m of flexible aluminium ducting GSA
- + 1 interior circular air valve BOR-100
- + 1 exterior mounted grille GR-100
- + 1 adhesive duct tape BA

The TD-250 T extractor is fitted with an adjustable Run-On- Timer between 1 and 30 minutes, keeping the fan in operation for the selected period of time after being switched off.



Installation and mounting

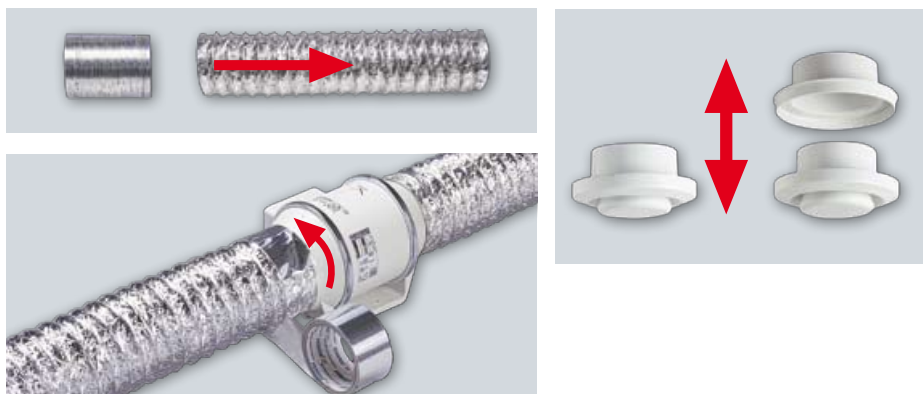
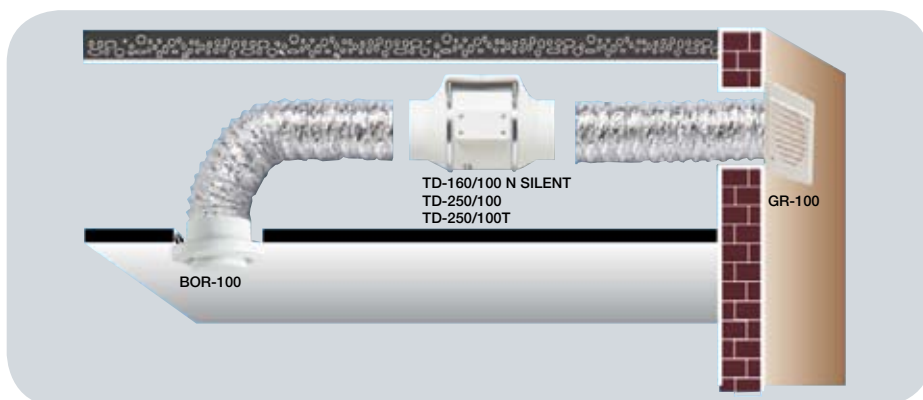

Accessories included in kit



GSA-100
100 mm diameter of flexible aluminium ducting



GR-100
Exterior mounted grille



BOR-100
Interior circular air valve



BA-50
Adhesive aluminium duct tape (10 m)